

STANLEY[®]

FATMAX[®]

FMHT77617

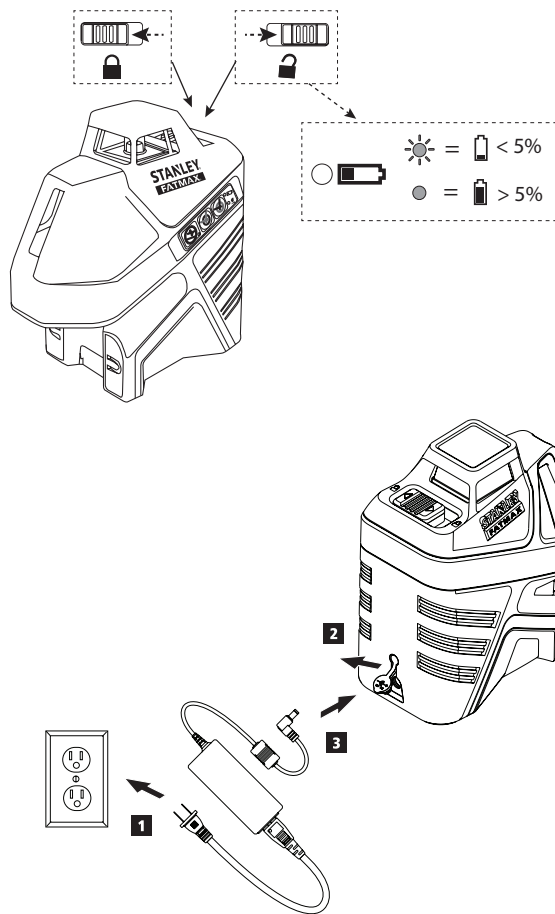

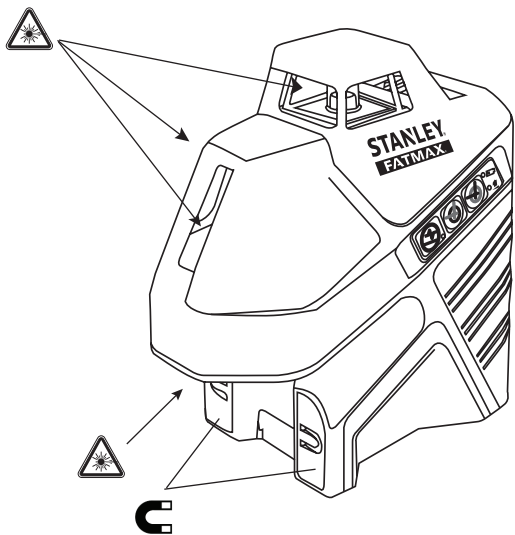
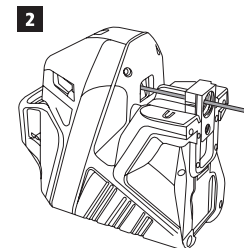
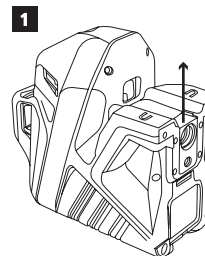
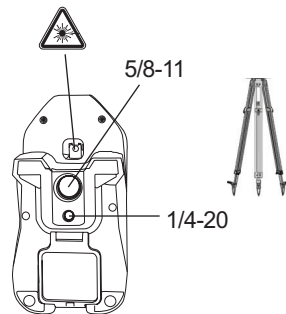
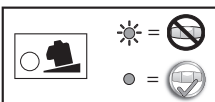
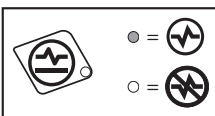
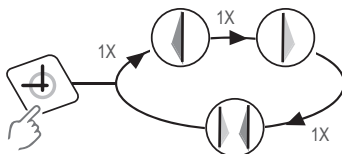
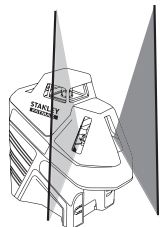
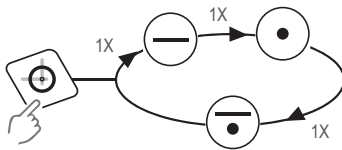
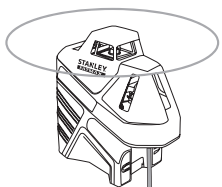

	LASER 2	
FMHT77617 $\leq 1.0\text{mW @ } 510\text{-}530\text{nm}$ $\leq 1.0\text{mW @ } 630\text{-}680\text{nm}$ IEC 60825-1: 2014		

Complies with 21 CFR 1040.10 and 1040.11 except for deviations pursuant to Laser Notice No. 50, dated June 24, 2007



© 2018 Stanley Black & Decker
Egide Walschaertsstraat 14-16
2800 Mechelen, Belgium



www.2helpU.com

P/N N593666 June 2018



Checking Accuracy ① → ④



DE Genauigkeitsprüfung
 DK Kontrol af nøjagtighed
 ES Comprobar la precisión
 ES-SA Comprobación de la precisión
 FIN Tarkkuuden tarkistaminen
 FR Vérification de la précision
 FR-CAN Vérification de la précision
 GR Έλεγχος ακρίβειας
 IT Controllo precisione
 NL Nauwkeurigheid controleren
 NO Kontrollere nøyaktighet
 PT Verificar a precisão
 PT-BRA Verificação da Precisão
 SE Kontroll av noggrannhet
 TR Doğruluk Kontrolü

①

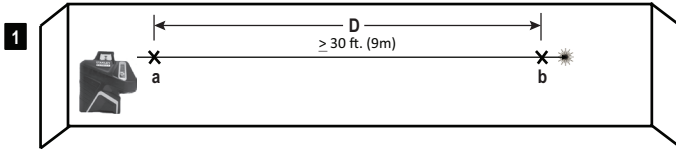

②

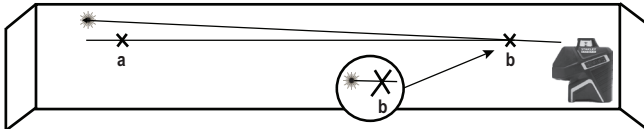

③

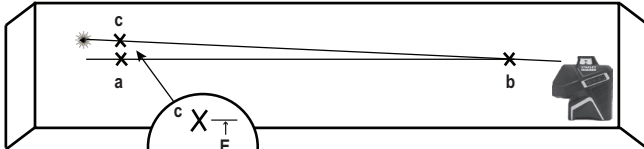

④

D	E
30' (9m)	1/4" (6.0mm)
40' (12m)	5/16" (8.0mm)
50' (15m)	13/32" (10.0mm)

②

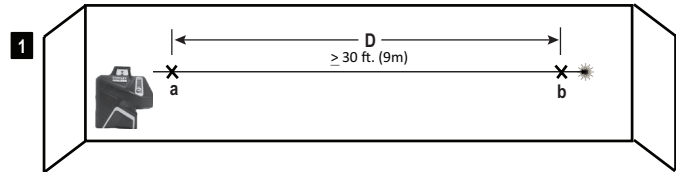

①



③

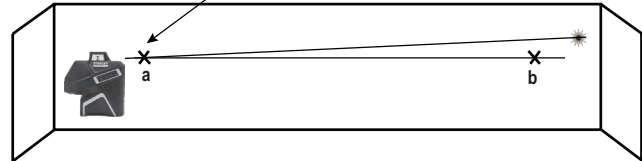

④

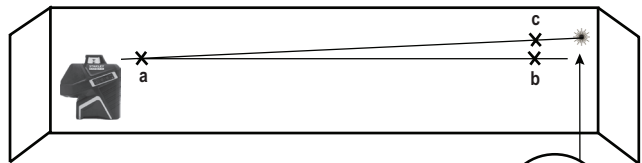

⑤

D	E
30' (9m)	1/4" (6.0mm)
40' (12m)	5/16" (8.0mm)
50' (15m)	13/32" (10.0mm)

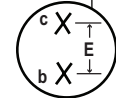

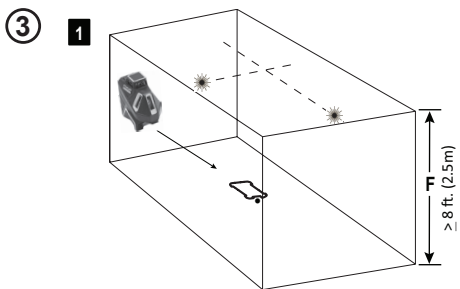

2 a, b, c

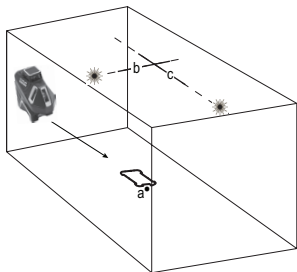

3

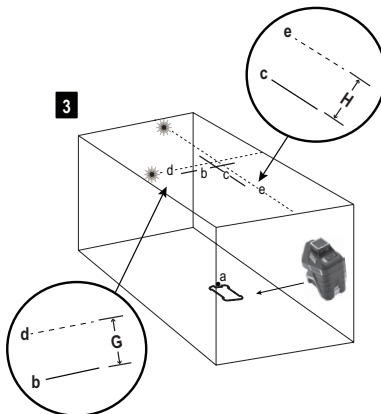

4

F	G, H
8' (2.5m)	1/16" (1.5mm)
10' (3m)	3/32" (2.0mm)
14' (4m)	1/8" (2.5mm)
20' (6m)	5/32" (4mm)
30' (9m)	1/4" (6mm)

4

1

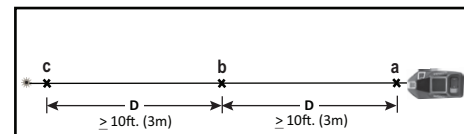

2

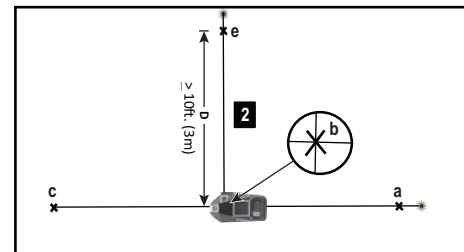

4

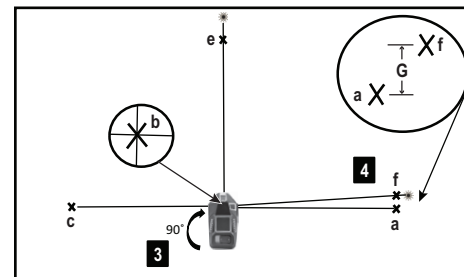

5

D	G
10' (3m)	1/8" (3.2mm)
14' (4m)	5/32" (3.5mm)
17' (5m)	3/16" (4.5mm)
20' (6m)	7/32" (5.5mm)
23' (7m)	1/4" (6mm)